

# Owner's Manual

## HDMI + Power over Cat5/6 Active Extender Kit

Model: B126-1A1-POC

Este manual esta disponible en español en la página de Tripp Lite:  
[triplite.com](http://triplite.com)

Ce manuel est disponible en français sur le site Web de Tripp Lite :  
[triplite.com](http://triplite.com)

### WARRANTY REGISTRATION

Register your product today and be automatically entered to win an ISOBAR<sup>®</sup> surge protector in our monthly drawing!

[triplite.com/warranty](http://triplite.com/warranty)



1111 W. 35th Street, Chicago, IL 60609 USA • [triplite.com/support](http://triplite.com/support)

Copyright © 2020 Tripp Lite. All rights reserved.

## Product Features

- Extends a 1080p (@ 60 Hz) signal up to 125 ft. from source
- Built-in Power over Cable (POC) technology powers receiver over Cat5e/6/6a cable
- Additional HDMI port on transmitter for connecting local display
- Built-in equalization control on receiver for adjusting video image
- Includes hardware for mounting both units on wall, rack or pole
- Supports up to 7.1-channel surround sound audio
- HDCP and 3D compatible
- Plug and play—no software or drivers necessary

## Package Includes

- B126-1A1-POC Transmitter Unit
- B126-1A1-POC Receiver Unit
- External Power Supply with NEMA 1-15P Plug (Input: 100–240V, 50/60 Hz, 0.5A; Output: 5V, 2A)
- Screwdriver for Equalization Adjustment
- Mounting Hardware
- Owner's Manual

## Optional Accessories

- N202-Series Cat6 24 AWG Solid-Wire Patch Cables
  - P568-Series High-Speed HDMI Cables
  - P569-XXX-LOCK\* High-Speed HDMI Cables with Ethernet and Locking Connectors
- \* Available in lengths up to 15 ft. XXX refers to length (e.g. 006 = 6 ft., 015 = 15 ft., etc.)

## Mounting Instructions

The B126-1A1-POC comes with mounting hardware that allows it to be mounted in a variety of ways. The following images show the different ways the included mounting brackets can be attached for different mounting methods.

### Wall-Mount



### 19-Inch Rack-Mount



### Pole-Mount



## Extender Kit Installation

### Notes:

1. Test to make sure the entire installation works properly before pulling cables through ceilings or walls.
2. To achieve maximum distance and performance, use 24 AWG solid-wire Cat5e/6 cable. Using stranded-wire Cat5e/6 cable or cable with a gauge (AWG) size higher than 24 AWG will result in shorter extension distance. Higher gauge cabling, such as 26 AWG, has a more limited transmission capability than lower gauge cabling. All Tripp Lite N202-Series Cat6 cables are made with 24 AWG solid-wire cabling.
3. Press the Audio button on the transmitter to switch between stereo and 7.1-channel surround sound audio. The unit is set to transmit stereo by default.

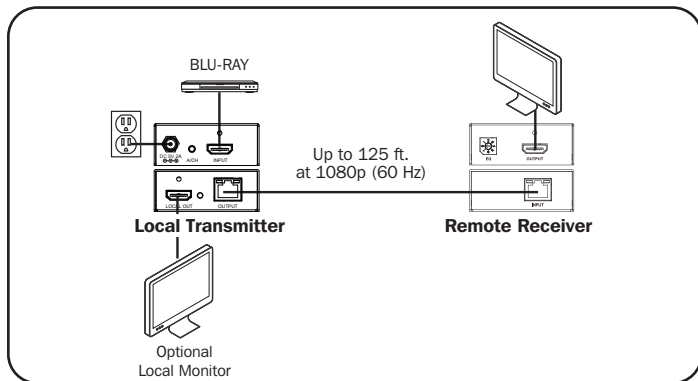

1. Make sure the HDMI source is turned OFF.
2. Connect the HDMI source to the INPUT port on the transmitter.
3. **Optional:** Connect a local monitor to the LOCAL port on the transmitter.
4. Connect the external power supply to the transmitter, and plug it into a Tripp Lite surge protector, power distribution unit (PDU) or uninterruptible power supply (UPS). The green RJ45 LED lights to indicate the unit is receiving power.

## Extender Kit Installation

5. Using a Cat5e/6 cable, connect the RJ45 port on the transmitter to the RJ45 port on the receiver. The green RJ45 LED on the receiver lights to indicate the unit is receiving power. The orange RJ45 LED lights to indicate the unit is connected to a transmitter that is powered on.
6. Connect the receiver's HDMI port to a monitor.
7. Turn on the power to the HDMI source. The orange RJ45 LED on the transmitter lights to indicate a signal is being received from the source.
8. If necessary, adjust the video image using the included screwdriver and the equalization control on the receiver.

*Note: An improper equalization setting can cause the monitor not to display an image at all. Try each equalization setting until an acceptable image is displayed.*

## Troubleshooting

If you are unable to get an acceptable image after following the installation instructions, try the troubleshooting tips below.

1. **Is the external power supply that came with the product connected and plugged into a working power source?** For the product to function properly, it must be connected to and receiving power from the external power supply.
2. **Was the power to the HDMI source turned off prior to installation?** If not, restart it.
3. **What resolution are you trying to reach?** See the Product Features and Installation sections in this manual for details on maximum distance and resolution. The shorter the extension distance, the higher the resolution you will be able to obtain. If you are not able to receive an acceptable image, try lowering your computer's video resolution or adjusting the refresh rate.
4. **What type of cabling are you using?** Inferior cabling can result in poor performance, so it is important you use cables that can support the video resolution you are trying to obtain. To achieve maximum distance and resolution, 24 AWG solid-wire UTP cable (such as Tripp Lite's N202-Series cables) must be used.

## Troubleshooting

- 5. Test your cables to ensure they are working properly.** For example, connect your Cat5e/6 cable between a computer and a network to verify it establishes a network connection.
- 6. Do you have any patch panels or other devices between the transmitter and receiver units?** Tripp Lite's HDMI + Power over Cat5/6 Active Extender Kit is designed to connect directly from the transmitter to the receiver via UTP cable. The more connection points that are between the source and the remote monitor, the more likely that signal degradation will occur, causing poor performance. If you have a patch panel or other device between, it should be removed from the installation.
- 7. Do you have a splitter, switch or other device between the computer and transmitter or between the receiver and display?** Tripp Lite's HDMI + Power over Cat5/6 Active Extender Kit is designed for the transmitter to connect directly with the source computer and for the receiver to connect directly to the display. If you have a splitter, switch or other device between, it should be removed from the installation.
- 8. Check your cabling for any damages that may have occurred during installation.** If a cable connector is loosened from being pulled through ceilings/walls or the cable jacket is damaged, causing the wiring to be exposed, you will not be able to achieve maximum performance.
- 9. Are the transmitter and/or receiver units located in an area that exposes them to elevated temperatures?** If the product is overheating, it will not function properly.

# Warranty and Product Registration

## 1-YEAR LIMITED WARRANTY

TRIPP LITE warrants its products to be free from defects in materials and workmanship for a period of one (1) year from the date of initial purchase. TRIPP LITE's obligation under this warranty is limited to repairing or replacing (at its sole option) any such defective products. To obtain service under this warranty, you must obtain a Returned Material Authorization (RMA) number from TRIPP LITE or an authorized TRIPP LITE service center. Products must be returned to TRIPP LITE or an authorized TRIPP LITE service center with transportation charges prepaid and must be accompanied by a brief description of the problem encountered and proof of date and place of purchase. This warranty does not apply to equipment, which has been damaged by accident, negligence or misapplication or has been altered or modified in any way.

EXCEPT AS PROVIDED HEREIN, TRIPP LITE MAKES NO WARRANTIES, EXPRESS OR IMPLIED, INCLUDING WARRANTIES OF MERCHANTABILITY AND FITNESS FOR A PARTICULAR PURPOSE.

Some states do not permit limitation or exclusion of implied warranties; therefore, the aforesaid limitation(s) or exclusion(s) may not apply to the purchaser.

EXCEPT AS PROVIDED ABOVE, IN NO EVENT WILL TRIPP LITE BE LIABLE FOR DIRECT, INDIRECT, SPECIAL, INCIDENTAL OR CONSEQUENTIAL DAMAGES ARISING OUT OF THE USE OF THIS PRODUCT, EVEN IF ADVISED OF THE POSSIBILITY OF SUCH DAMAGE.

Specifically, TRIPP LITE is not liable for any costs, such as lost profits or revenue, loss of equipment, loss of use of equipment, loss of software, loss of data, costs of substitutes, claims by third parties, or otherwise.

## PRODUCT REGISTRATION

Visit [triplite.com/warranty](http://triplite.com/warranty) today to register your new Tripp Lite product. You'll be automatically entered into a drawing for a chance to win a FREE Tripp Lite product!\*

\* No purchase necessary. Void where prohibited. Some restrictions apply. See website for details.

# Warranty and Product Registration

## FCC Notice, Class B

This device complies with part 15 of the FCC Rules. Operation is subject to the following two conditions: (1) This device may not cause harmful interference, and (2) this device must accept any interference received, including interference that may cause undesired operation.

Note: This equipment has been tested and found to comply with the limits for a Class B digital device, pursuant to part 15 of the FCC Rules. These limits are designed to provide reasonable protection against harmful interference in a residential installation. This equipment generates, uses and can radiate radio frequency energy and, if not installed and used in accordance with the instructions, may cause harmful interference to radio communications. However, there is no guarantee that interference will not occur in a particular installation. If this equipment does cause harmful interference to radio or television reception, which can be determined by turning the equipment off and on, the user is encouraged to try to correct the interference by one or more of the following measures:

- Reorient or relocate the receiving antenna.
- Increase the separation between the equipment and receiver.
- Connect the equipment into an outlet on a circuit different from that to which the receiver is connected.
- Consult the dealer or an experienced radio/TV technician for help.

Any changes or modifications to this equipment not expressly approved by Tripp Lite could void the user's authority to operate this equipment.

## WEEE Compliance Information for Tripp Lite Customers and Recyclers (European Union)



Under the Waste Electrical and Electronic Equipment (WEEE) Directive and implementing regulations, when customers buy new electrical and electronic equipment from Tripp Lite they are entitled to:

- Send old equipment for recycling on a one-for-one, like-for-like basis (this varies depending on the country)
- Send the new equipment back for recycling when this ultimately becomes waste

Use of this equipment in life support applications where failure of this equipment can reasonably be expected to cause the failure of the life support equipment or to significantly affect its safety or effectiveness is not recommended.

Tripp Lite has a policy of continuous improvement. Specifications are subject to change without notice. Photos and illustrations may differ slightly from actual products.



1111 W. 35th Street, Chicago, IL 60609 USA • [triplite.com/support](http://triplite.com/support)