

Owner's Manual

HDMI over Powerline Active Extender Kit

Model: B126-1A1-PLHD

Este manual esta disponible en español en la página de Tripp Lite:
www.tripplite.com/support

Ce manuel est disponible en français sur le site Web de Tripp Lite :
www.tripplite.com/support



Do not plug this unit into an extension cord, power strip, surge protector, or outlet with a Ground Fault Circuit Interrupter (GFCI) or Arc Fault Circuit Interrupter (AFCI) circuit.



1111 W. 35th Street, Chicago, IL 60609 USA • www.tripplite.com/support

Copyright © 2018 Tripp Lite. All rights reserved.

Package Contents

- Transmitter Unit
- Receiver Unit
- IR-IN Cable
- IR-OUT Cable
- (2) C7 to NEMA 1-15P Power Cords, 4 ft.
- Mounting Hardware
- Owner's Manual

Optional Accessories

- P568-Series High-Speed HDMI Cables
 - P569-XXX-LOCK* High-Speed HDMI Cables with Ethernet and Locking Connectors
- *XXX refers to the length. Cables are available in 6 ft. (006), 10 ft. (010) and 15 ft. (015) lengths.

System Requirements

- Source device with an HDMI port (Blu-ray player, computer, laptop)
- Display device with an HDMI port (HDTV, projector, monitor)
- 100–120V AC power input

Product Features

- Extends HDMI audio/video and IR control signals up to 300 m (984 ft.) from the source
- Uses existing power outlets to extend a 1080p signal up to 300 m @ 60 Hz
- IR control functionality for controlling the HDMI source device remotely
- HDMI output port on transmitter for connecting an additional display
- Supports high-definition video and stereo audio
- Supports 24-bit Deep Color (8 bits per channel)
- Compatible with HDMI 1.3 and HDCP 1.2 standards
- Supports 300 MHz/3.4 Gbps per channel bandwidth (10.2 Gbps total)
- Plug-and-play operation with no software or drivers required

Product Overview

Transmitter and Receiver Front Panel

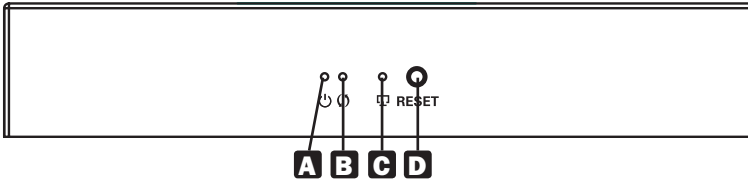

- A Power LED (Blue)**—Illuminates to indicate the unit is receiving power.
- B Data Transmission LED (Yellow)**—Blinks slowly while connection is building. Blinks quickly when unit is successfully connected and transmitting data.
- C Connection LED (Green)**—Blinks when signal is connected.
- D Reset Button**—Press to restart the unit.

Transmitter Back Panel

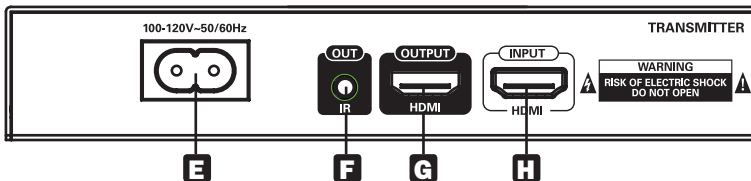

- E C8 AC Power Input**—Connects to included 4 ft. C7 to NEMA 1-15P power cord.
- F IR-OUT Connector (Female)**—Connects to included IR-OUT cable. IR blaster cable should be placed close to source device for best results.
- G HDMI Output Connector (Female)**—Connects to local HDMI display with HDMI cable (sold separately).
- H HDMI Input Connector (Female)**—Connects to HDMI source with HDMI cable (sold separately).

Receiver Back Panel

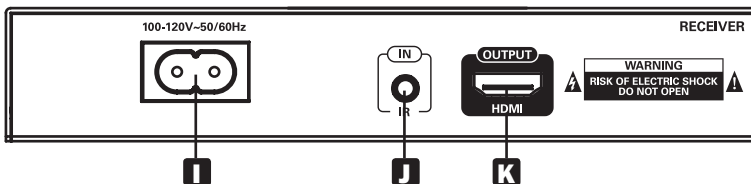

- I C8 AC Power Input**—Connects to included 4 ft. C7 to NEMA 1-15P power cord.
- J IR-IN Connector (Female)**—Connects to included IR-IN cable. Source remote control must be within the required range of the IR receiver.
- K HDMI Output Connector (Female)**—Connects to local HDMI display with HDMI cable (sold separately).

Installation

Notes:

- Make sure all equipment being connected is powered off prior to installation.



This product requires that the transmitter and receiver be plugged into power outlets that are on the same power circuit, and should not be connected through an extension cord, power strip or surge protector. For optimal performance, plug directly into a wall socket.



Connection issues may arise if the transmitter and receiver are connected to an electrical circuit with a Ground Fault Interrupter (GFCI) or Arc Fault Circuit Interrupter (AFCI), and if the power outlet is located near an appliance with high power consumption, such as a washer or dryer. It is recommended to avoid this if possible.

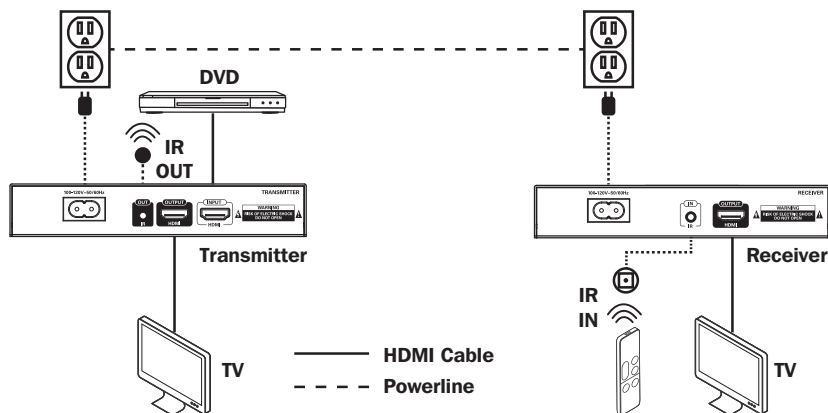

- 1. Optional:** Attach the included mounting hardware to the transmitter and receiver units, and mount them to a desired location.
- 2.** Connect the HDMI source device to the HDMI Input port on the transmitter using an HDMI cable, such as Tripp Lite's P568-Series High-Speed HDMI Cables.
- 3.** Connect an HDMI display to the HDMI output port on the transmitter using an HDMI cable, such as Tripp Lite's P568-Series High-Speed HDMI Cables.
- 4.** Connect the IR-OUT (Tx) cable to the IR-OUT port on the transmitter.
Note: IR-OUT cable has IR-OUT marked on the bottom of the IR bulb. Place the bulb of the IR-OUT cable in an area with a direct line of sight to the HDMI source device (e.g. Blu-Ray player).
- 5.** Connect an included AC power cord to the transmitter, and plug it directly into a wall outlet.
- 6.** Connect the HDMI display to the HDMI Output port on the receiver using a P568-Series High-Speed HDMI Cable.
- 7.** Connect the IR-IN (Rx) extension cable to the IR-IN port on the receiver unit.
Note: IR Receiver cable has IR-IN marked on the bottom of the IR bulb. Place the bulb of the IR receiver cable in the general area you will be using the source device's remote control.
- 8.** Connect the other included AC power cord to the receiver, and plug it directly into an electrical wall outlet.
- 9.** Turn on power to the connected equipment.

Troubleshooting

If you are unable to get an acceptable image after following the installation instructions, try the troubleshooting tips below.

- 1. Are the AC power cords that came with the product connected and plugged into a working power source?** For the product to function properly, the transmitter and receiver must be connected to and receiving power from an external power source.
- 2. Are the transmitter and receiver units plugged into power outlets that are on the same electrical circuit?** If not, they will not function properly.
- 3. Is the transmitter and/or receiver unit plugged into an extension cord, power strip, or surge protector?** If so, disconnect and plug the units directly into a wall socket.
- 4. Are the transmitter and receiver connected to an electrical circuit with a GFCI or AFCI, or connected to an outlet located near a high power consumption device (e.g. washer, dryer, etc)?** This may cause poor performance, and you should try plugging into an outlet that avoids these things.
- 5. Was the power to the HDMI source turned off prior to installation?** If not, restart.
- 6. What resolution are you trying to reach?** See the **Product Features** and **Installation** sections in this manual for details on maximum distance and resolution. If you are not able to get an acceptable image, try lowering your computer's video resolution or adjusting the refresh rate.
- 7. Does your HDMI display have a message saying "Waiting for Connection" in the bottom right corner?** If so, please check to make sure the AC power cords are properly connected and the power indicator LEDs are solid.
- 8. Does your HDMI display have a message saying "Please Check the TX Input Signal?"** Please check that the HDMI signal connection on the transmitter is solid. If the signal is not solid, connect the source device directly to the display device to see if the issue is with the source, display or HDMI cable you are using.
- 9. Is the HDMI display transmitting a choppy picture?** If so, make sure the position of the transmitter and receiver are in the required range, and then press the reset button on the receiver panel to reconnect. If this does not work, check for other signal disturbances between the transmitter and receiver.
- 10. Test your cables to ensure they are working properly.**
- 11. Are the transmitter and/or receiver located in an area that exposes them to elevated temperatures?** If the product is overheating, it will not function properly.

Specifications

Specification	Value
Input Port	HDMI (F); 3.5 mm (F)
Output Port	(x2) HDMI (F); 3.5 mm (F)
IR Frequency	20–60 Hz Wide Range
Transmission Distance	300 m (984.3 ft.)
Voltage	AC 100–120V
Power Consumption	Tx: 7.5W; Rx: 7W
HDMI Version	1.3
HDCP Version	1.2
Max Video Resolutions	1920 x 1080/1080p @ 60 Hz
MTBF	>30,000 hours
Operating Temperature	32° to 140° F (0° to 60° C)
Storage Temperature	-4° to 158° F (-20° to 70° C)
Humidity	0 to 95% RH, Non-Condensing
Unit Dimension (H x W x D, in.)	6.2 x 3.5 x 1.1
Unit Dimension (H x W x D, mm)	158 x 89 x 28
Unit Weight (lb.)	Tx: 0.96; Rx: 0.98
Unit Weight (g)	Tx: 435; Rx: 445

Warranty and Product Registration

1-Year Limited Warranty

Tripp Lite warrants its products to be free from defects in materials and workmanship for a period of one (1) year from the date of initial purchase. Tripp Lite's obligation under this warranty is limited to repairing or replacing (at its sole option) any such defective products. To obtain service under this warranty, you must obtain a Returned Material Authorization (RMA) number from Tripp Lite or an authorized Tripp Lite service center. Products must be returned to Tripp Lite or an authorized Tripp Lite service center with transportation charges prepaid and must be accompanied by a brief description of the problem encountered and proof of date and place of purchase. This warranty does not apply to equipment, which has been damaged by accident, negligence or misapplication or has been altered or modified in any way.

EXCEPT AS PROVIDED HEREIN, Tripp Lite MAKES NO WARRANTIES, EXPRESS OR IMPLIED, INCLUDING WARRANTIES OF MERCHANTABILITY AND FITNESS FOR A PARTICULAR PURPOSE. Some states do not permit limitation or exclusion of implied warranties; therefore, the aforesaid limitation(s) or exclusion(s) may not apply to the purchaser.

EXCEPT AS PROVIDED ABOVE, IN NO EVENT WILL Tripp Lite BE LIABLE FOR DIRECT, INDIRECT, SPECIAL, INCIDENTAL OR CONSEQUENTIAL DAMAGES ARISING OUT OF THE USE OF THIS PRODUCT, EVEN IF ADVISED OF THE POSSIBILITY OF SUCH DAMAGE. Specifically, Tripp Lite is not liable for any costs, such as lost profits or revenue, loss of equipment, loss of use of equipment, loss of software, loss of data, costs of substitutes, claims by third parties, or otherwise.

PRODUCT REGISTRATION

Visit www.triplite.com/warranty today to register your new Tripp Lite product. You'll be automatically entered into a drawing for a chance to win a FREE Tripp Lite product!*

* No purchase necessary. Void where prohibited. Some restrictions apply. See website for details.

FCC Notice, Class B

This device complies with part 15 of the FCC Rules. Operation is subject to the following two conditions: (1) This device may not cause harmful interference, and (2) this device must accept any interference received, including interference that may cause undesired operation.

Note: This equipment has been tested and found to comply with the limits for a Class B digital device, pursuant to part 15 of the FCC Rules. These limits are designed to provide reasonable protection against harmful interference in a residential installation. This equipment generates, uses and can radiate radio frequency energy and, if not installed and used in accordance with the instructions, may cause harmful interference to radio communications. However, there is no guarantee that interference will not occur in a particular installation. If this equipment does cause harmful interference to radio or television reception, which can be determined by turning the equipment off and on, the user is encouraged to try to correct the interference by one or more of the following measures:

- Reorient or relocate the receiving antenna.
- Increase the separation between the equipment and receiver.
- Connect the equipment into an outlet on a circuit different from that to which the receiver is connected.
- Consult the dealer or an experienced radio/TV technician for help.

Any changes or modifications to this equipment not expressly approved by Tripp Lite could void the user's authority to operate this equipment.

WEEE Compliance Information for Tripp Lite Customers and Recyclers (European Union)



Under the Waste Electrical and Electronic Equipment (WEEE) Directive and implementing regulations, when customers buy new electrical and electronic equipment from Tripp Lite they are entitled to:

- Send old equipment for recycling on a one-for-one, like-for-like basis (this varies depending on the country)
- Send the new equipment back for recycling when this ultimately becomes waste

Use of this equipment in life support applications where failure of this equipment can reasonably be expected to cause the failure of the life support equipment or to significantly affect its safety or effectiveness is not recommended. Do not use this equipment in the presence of a flammable anesthetic mixture with air, oxygen or nitrous oxide.

Tripp Lite has a policy of continuous improvement. Specifications are subject to change without notice.



1111 W. 35th Street, Chicago, IL 60609 USA • www.tripplite.com/support